

FLEX

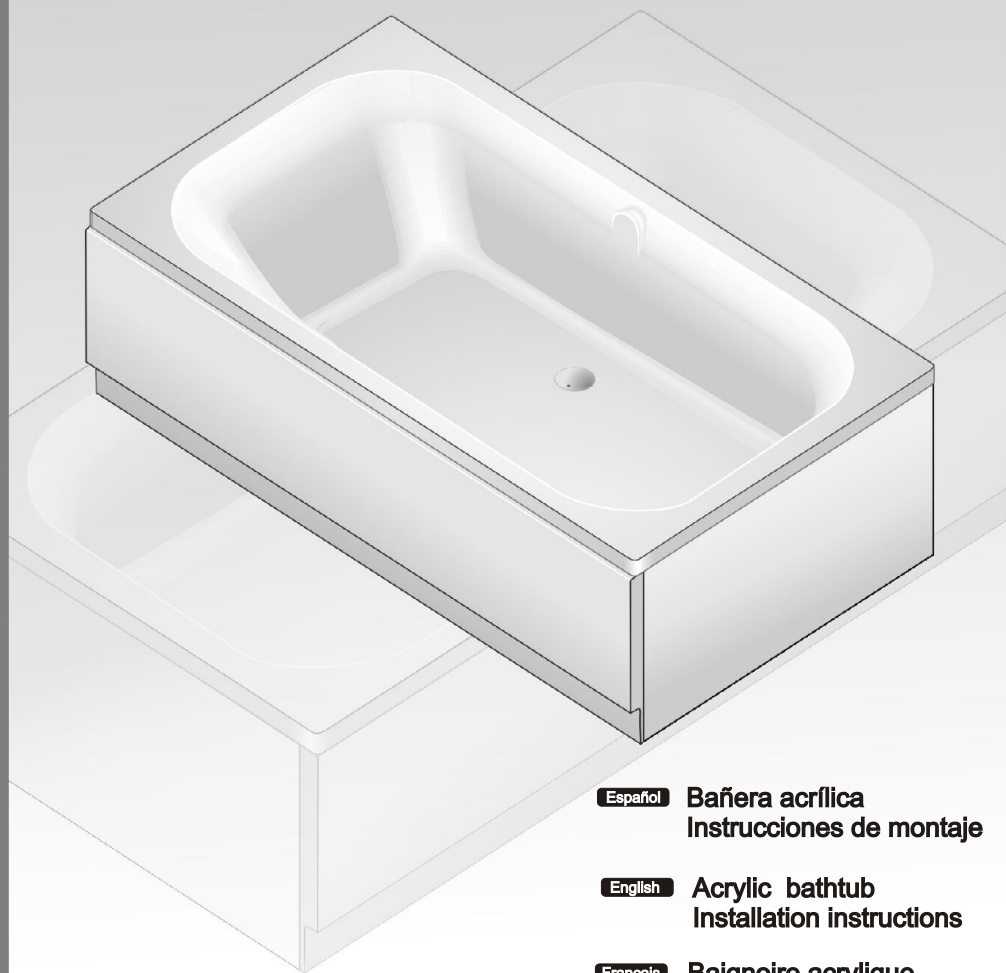

Español Bañera acrílica
Instrucciones de montaje

English Acrylic bathtub
Installation instructions

Français Baignoire acrylique
Instructions de montage

 **gala**

BAÑERA ACRÍLICA - ACRYLIC BATHTUB - Baignoire Acrylique

Fig-1

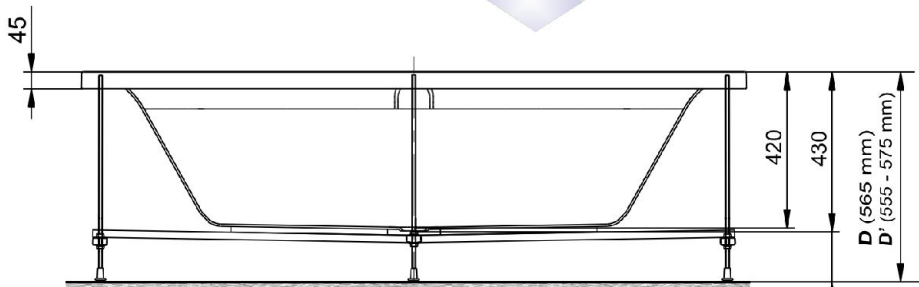
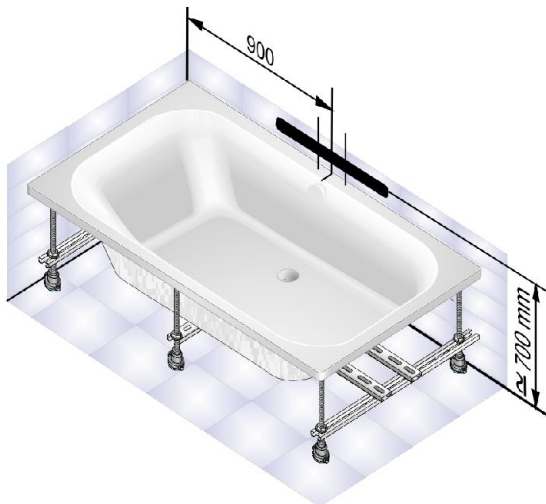

E / D (con faldón) / (with apron) / (avec tablier)

E' / D' (sin faldón) / (without apron) / (sans tablier)

E (135 mm)
E' (125 / 145 mm)

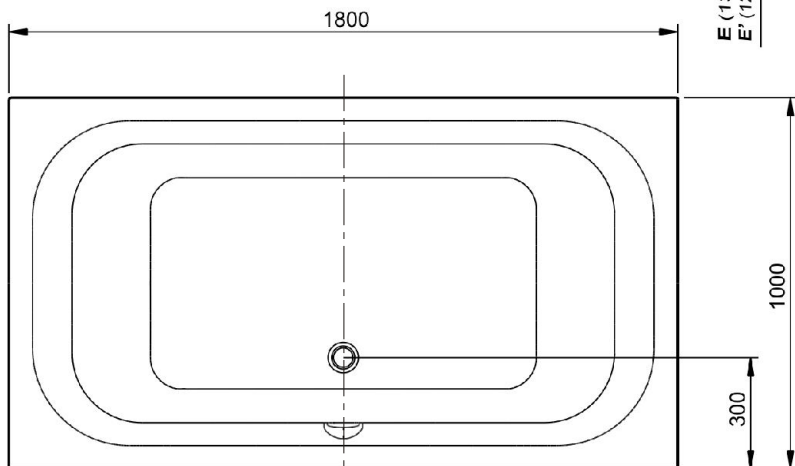

INSTALACIÓN BASTIDOR - INSTALLATION METAL FRAME - INSTALLATION CHÂSSIS

- 1 Únicamente para bañeras (sin hidromasaje) con el bastidor sin fijar
- 2 Only for bathtubs (without hydromassage) with not fixed metal frame
- 3 Uniquement pour les baignoires (sans hydromassage) avec le châssis sans fixer

1

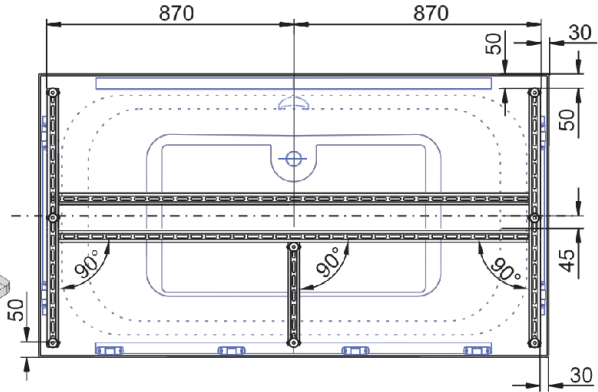
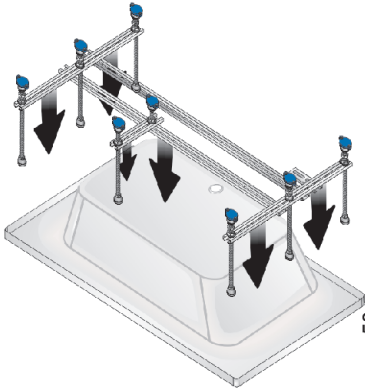

2

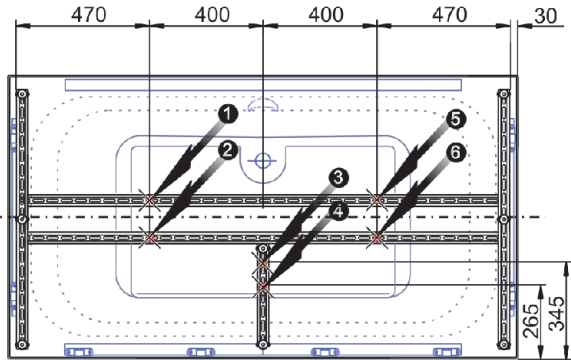
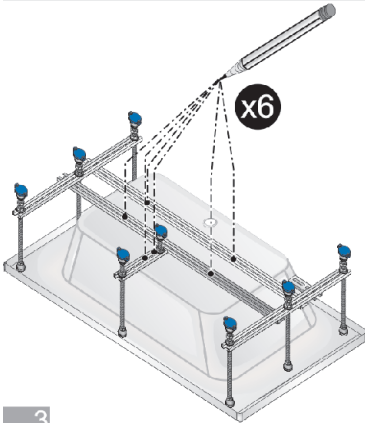

3

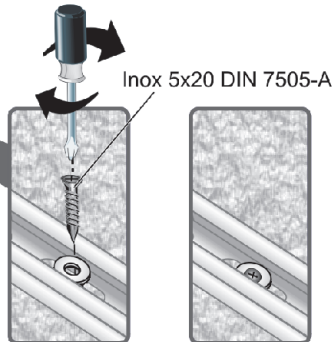
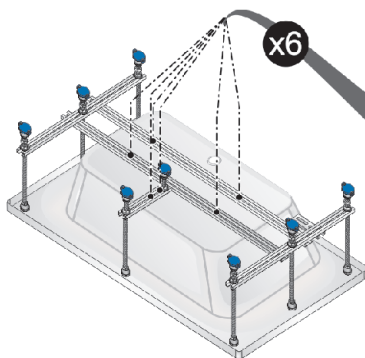

Español

Proteger la bañera antes de proceder a su instalación.

Realizar el tendido de tuberías de alimentación y desagüe situando la grifería según, Fig-1.

Revestir paredes y suelo.

Colocar los soportes de apoyo (no suministrados) distribuyéndolos uniformemente y depositar silicona según Fig-2.

Antes de colocar la bañera en su emplazamiento, montar la grifería. (La ubicación que se muestra en Fig. 1 es únicamente a título orientativo).

Colocar la bañera. **Regular la altura y nivelar.**

Fijar los pies al suelo.

Conectar el desagüe intercalando un elemento elástico.

Efectuar el revestimiento mural de la bañera o, en su caso, montar el faldón.

Llenar la bañera de agua y sellar las uniones con silicona según Fig-3.

Sin pies:

En las bañeras instaladas sin soporte metálico, deberá realizarse la obra necesaria con ladrillos o lecho de arena.

English

Protect the bathtub before its installation.

Install the water supply and drainage piping, placing the taps as shown in Fig-1.

Install floor and wall coverings.

Place supports (not included) uniformly and apply silicone as shown in Fig-2.

Before positioning the bathtub, install the taps. (The position showed in Fig-1 is only a guide).

Place the bathtub. **Regulate height and set level.**

Position the legs and secure them to the floor.

Connect the drainage pipe using an elastic joint.

Build the bathtub fronting or, if applicable, install the skirting.

Fill the bathtub with water and seal all joints with silicone, as shown in Fig-3.

Without legs:

For steel bathtubs without a metal support structure, mounting must be performed with bricks or sanded.

Français

Protéger la baignoire avant de procéder à son installation.

Poser les tuyauteries d'alimentation et d'écoulement des eaux en plaçant la robinetterie conformément à la Fig-1.

Revêtir les murs et le sol.

Placer des appuis (pas inclus) de manière uniforme et poser la silicone conformément à la Fig-2.

Avant d'installer la baignoire dans l'emplacement qui lui est réservé, monter la robinetterie. (La situation décrite dans la Fig-1 est uniquement à titre indicatif).

Installer la baignoire. **Régler la hauteur et mettre à niveau.**

Asseoir les pieds et les fixer au sol.

Raccordez le tuyau d'écoulement des eaux en intercalant un élément élastique.

Effectuer le revêtement mural de la baignoire ou, le cas échéant, monter le tablier.

Remplir la baignoire d'eau et sceller les jointures avec de la silicone, conformément à la Fig-3.

Sans pieds:

Dans les baignoires installées sans support métallique, l'installation se fera avec des briques ou un lit de sable.

INSTALACIÓN PARA BAÑERA SIN EMPOTRAR
 INSTALLATION FOR NOT BUILT-IN BATH-TUB
 INSTALLATION POUR BAIGNOIRE SANS ENCASTRER

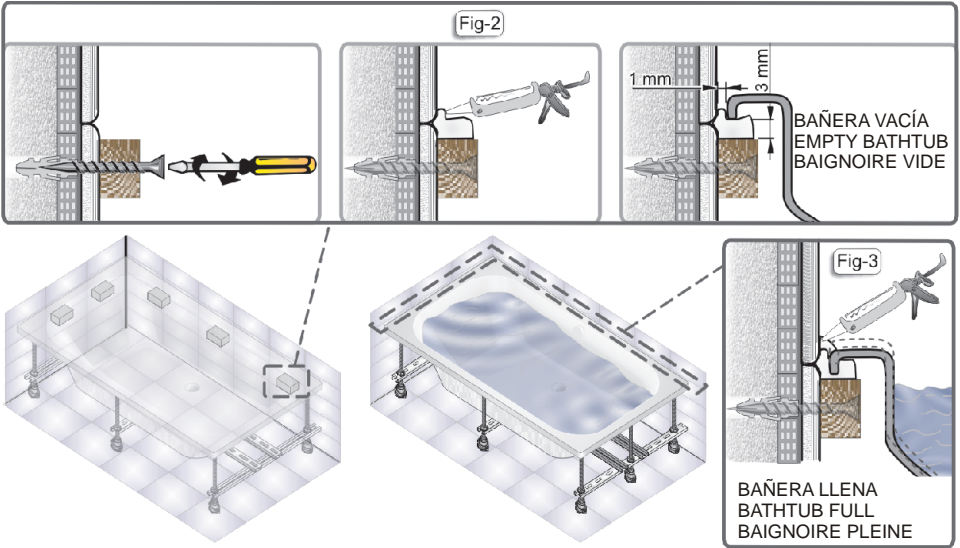

INSTALACIÓN PARA BAÑERA EMPOTRADA
 INSTALLATION FOR BUILT-IN BATH-TUB
 INSTALLATION POUR BAIGNOIRE ENCASTRÉE

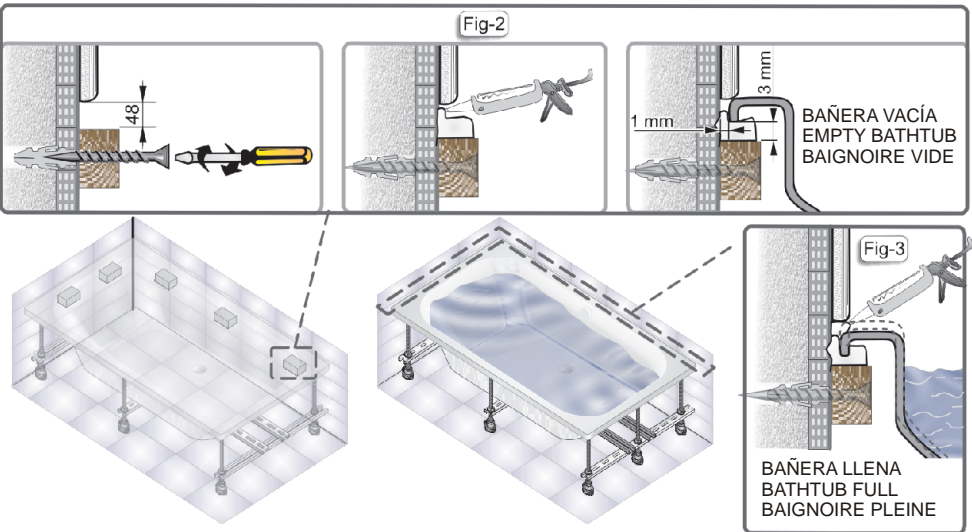

6



Para la instalación del **faldón Frontal** seguir los siguientes pasos:
 To install the **Front panel** follow these steps:
 Pour installer le **tablier Frontal**, suivez les pas suivants:

1 2 3 4 5



Para la instalación del **faldón Lateral Derecho** seguir los siguientes pasos:
 To install the **Side Right panel**, please follow these steps:
 Pour installer le **tablier Latéral Droit**, suivez les indications suivantes:

6 7 8 9 10 11



Para la instalación del **faldón Lateral Izquierdo** seguir los siguientes pasos:
 To install the **Side Left panel**, please follow these steps:
 Pour installer le **tablier Latéral Gauche**, suivez les indications suivantes:

12 13 14 15 16 17

INSTALACIÓN FALDÓN FRONTAL - INSTALLATION OF FRONTAL PANEL - INSTALLATION DE TABLIER FRONTAL

1

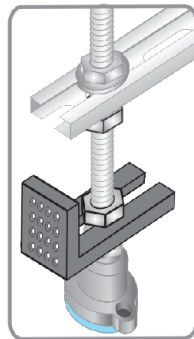
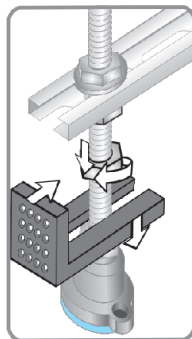

2

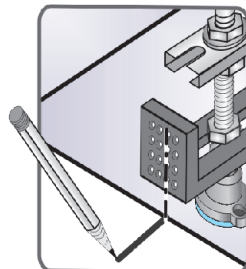
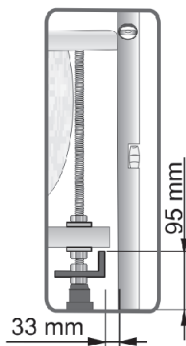

3



3 Únicamente para bañeras empotradas en la pared

3 Only for bathtubs that are built-in on the wall

3 Uniquement pour des baignoires encastrées au mur

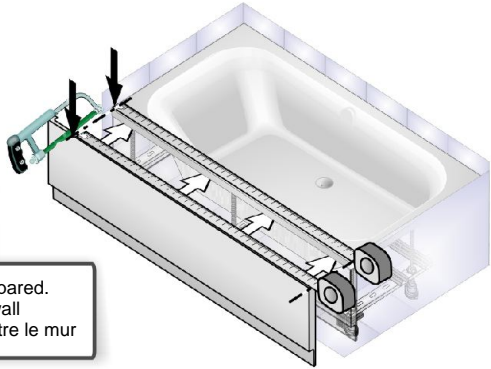

Cortar el faldón por la parte próxima a la pared.
Cut the panel by the part next to the wall
Couper le tablier sur la partie qui repose contre le mur

4

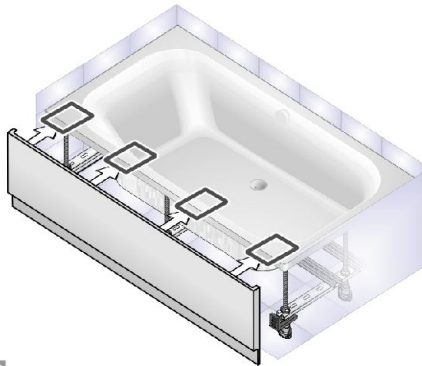

5 mm

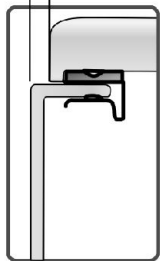
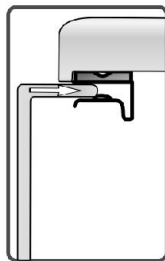

5

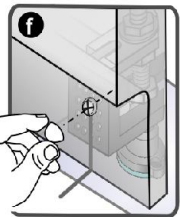
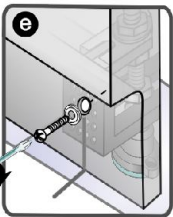
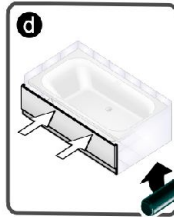
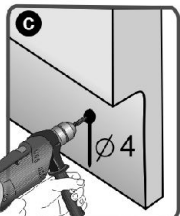
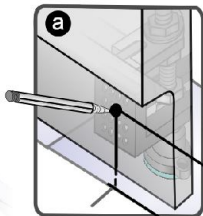
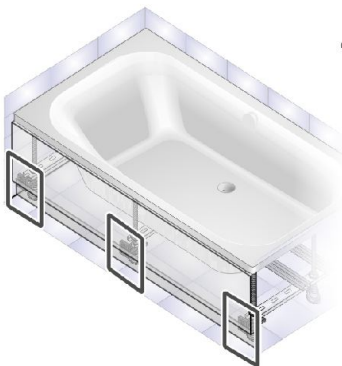

INSTALACIÓN FALDÓN LATERAL DERECHO - INSTALLATION OF SIDE RIGHT PANEL - INSTALLATION DE TABLIER LATÉRAL DROIT

6

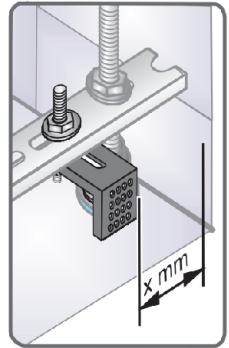
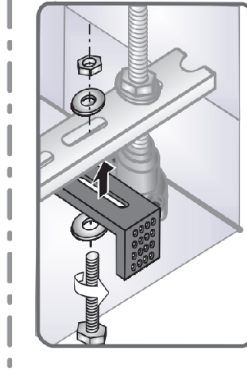

7

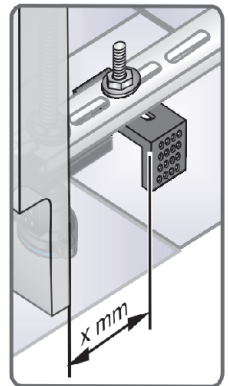
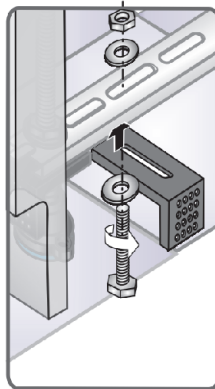

8

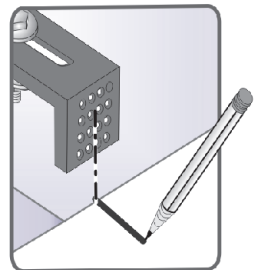
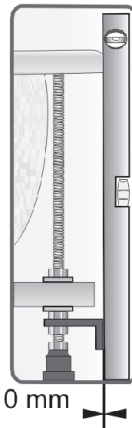

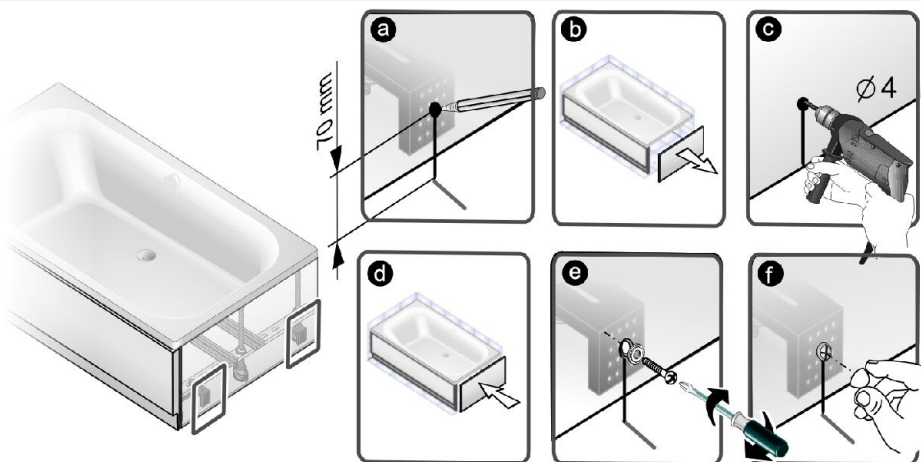
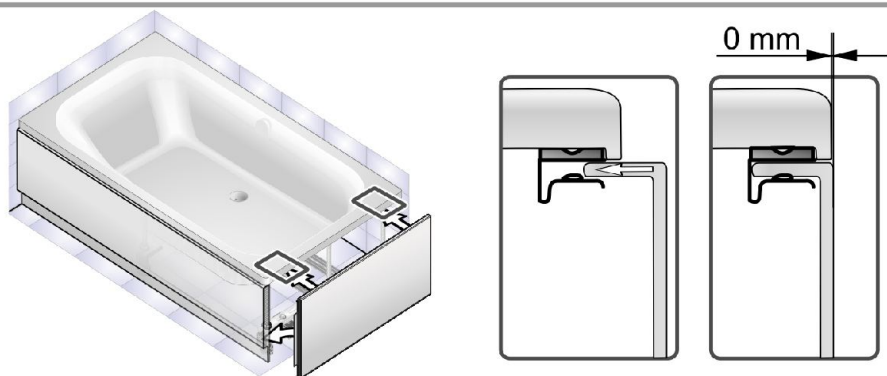
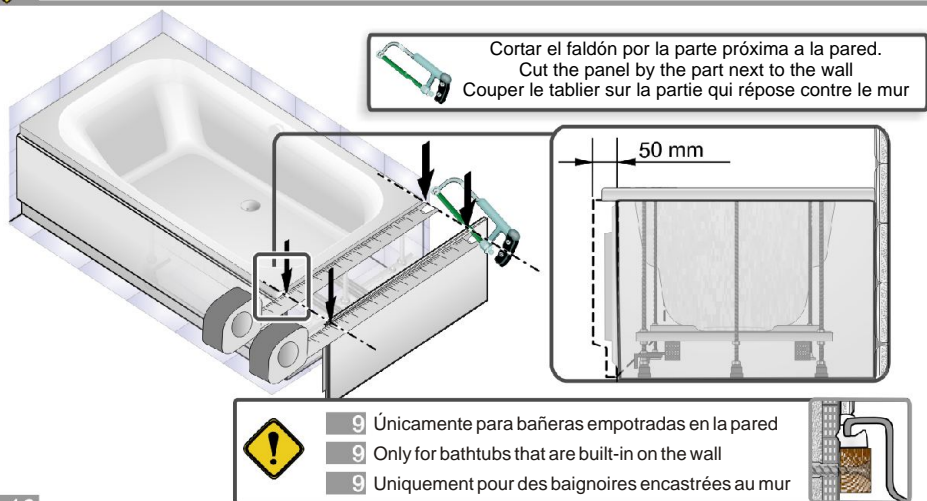

INSTALACIÓN FALDÓN LATERAL IZQUIERDO - INSTALLATION OF SIDE LEFT PANEL -
INSTALLATION DE TABLIER LATÉRAL GAUCHE

12

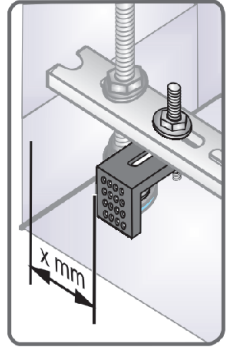
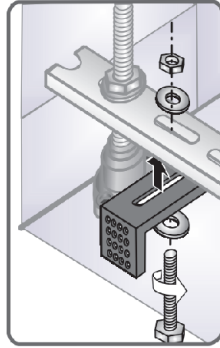
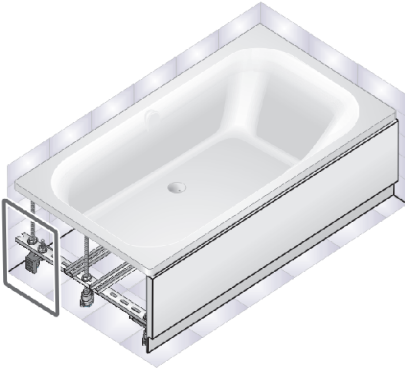

13

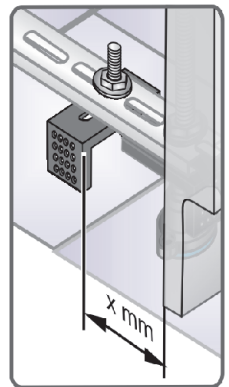
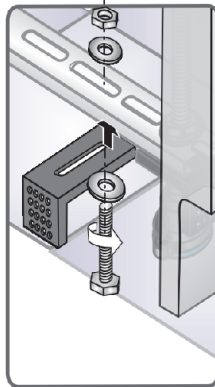
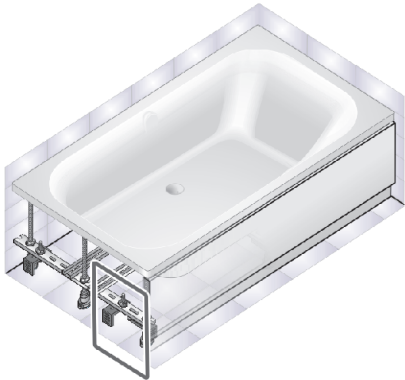

14

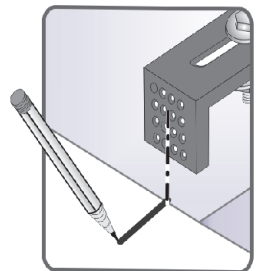
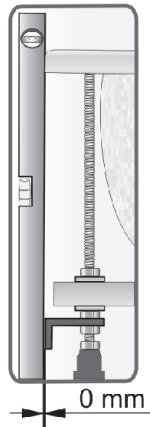

15



- 15 Únicamente para bañeras empotradas en la pared
- 15 Only for bathtubs that are built-in on the wall
- 15 Uniquement pour des baignoires encastrées au mur

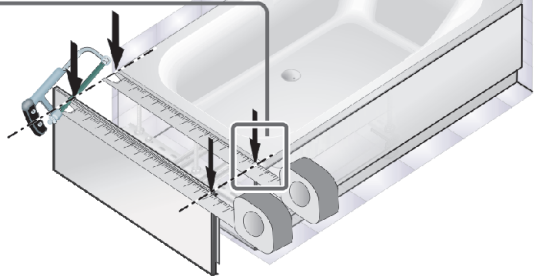
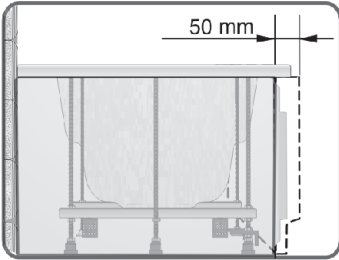
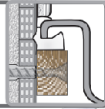

Cortar el faldón por la parte próxima a la pared.
 Cut the panel by the part next to the wall
 Couper le tablier sur la partie qui repose contre le mur

16

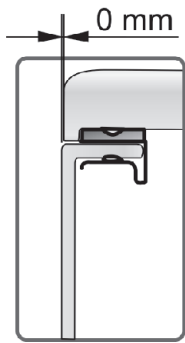
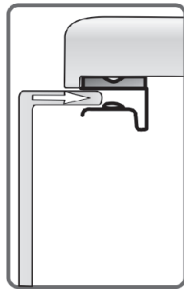
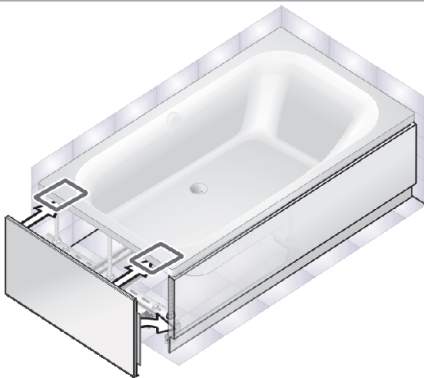

17

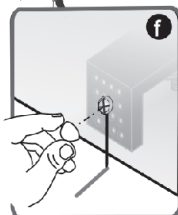
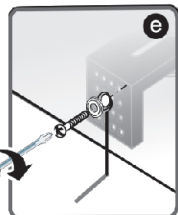
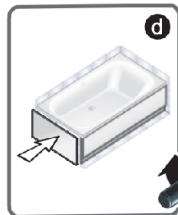
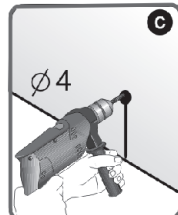
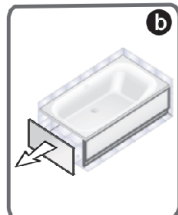
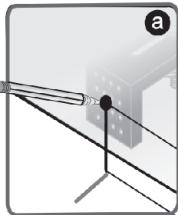



CERÁMICAS GALA, S.A.

Ctra. Madrid - Irún, Km. 244
Apartado de Correos, 293
09080 BURGOS - ESPAÑA
www.gala.es

☎ +34-947 47 41 00

☎ +34-947 47 41 03

e-mail: general@gala.es

G6361118000-25/08/08